

Utensili per presse piegatrici realizzati con standards di qualità superiore, temprati a induzione sulle parti di lavoro e totalmente rettificati. Mat.: acciaio C 50 (50-52 HRC) ★ - Mat.: UNI EN 10083/1 - ISO 683 - (42CrM04) - (53-60 HRC)★★

Press Brake Tooling in best quality, induction hardened and ground on the working surfaces. Mat.: CK 50 (50-52 HRC)★ - Mat.: UNI EN 10083/1 - ISO 683 - (42CrM04) - (53-60 HRC)★★

★ 2008

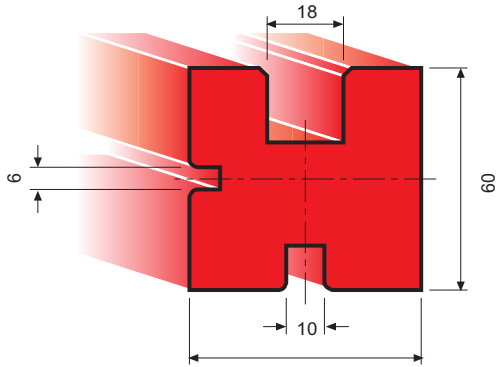

SOLID 100 T / m



★ ★★ 2009

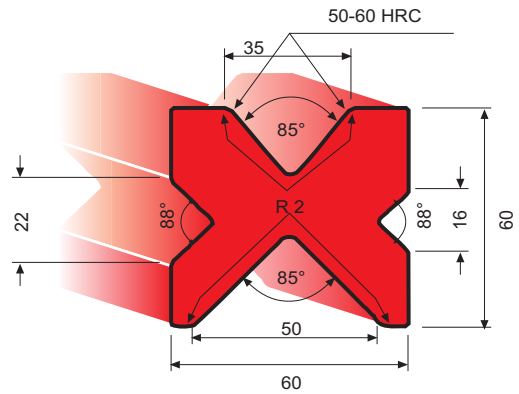

SOLID 100 T / m



★★ 2009 / 85°

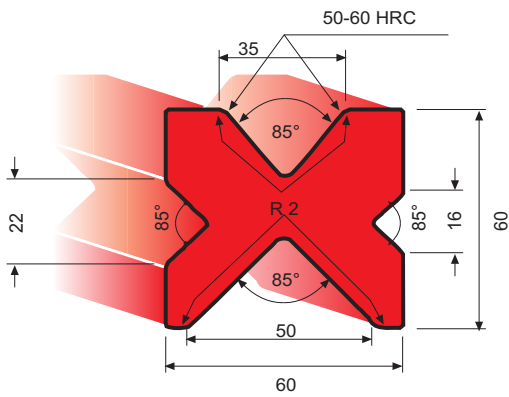

SOLID 100 T / m



★ 2009 / 60°

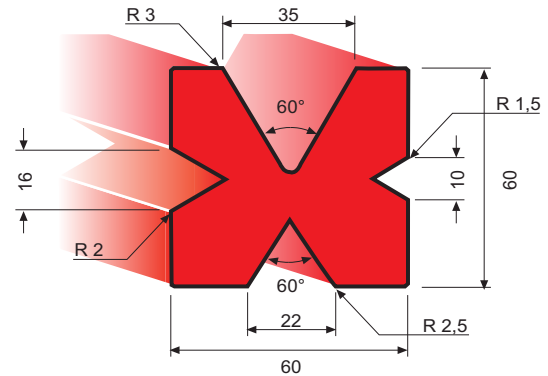

SOLID 80 T / m



★ 2009 / SPEC

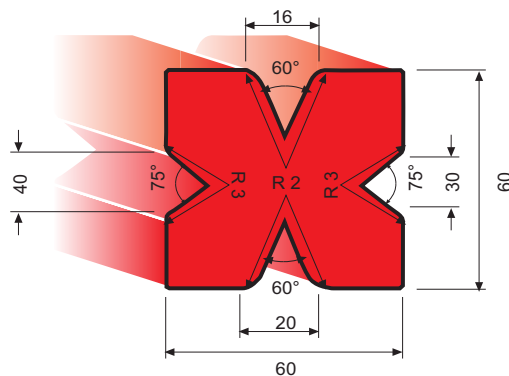

SOLID 30 T / m



★★ 2011 / A / 18 / 30°

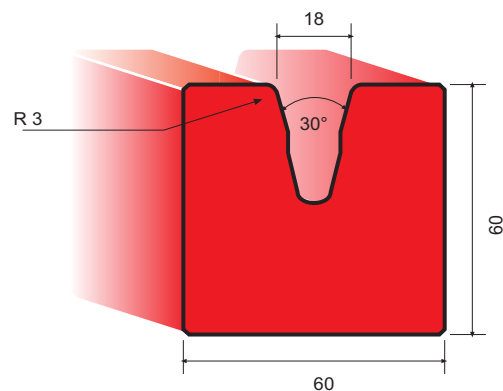

SOLID 80 T / m



Utensili per presse piegatrici realizzati con standards di qualità superiore, temprati a induzione sulle parti di lavoro e totalmente rettificati. Mat.: acciaio C 50 (50-52 HRC) ★ - Mat.: UNI EN 10083/1 - ISO 683 - (42CrM04) - (53-60 HRC)★★

Press Brake Tooling in best quality, induction hardened and ground on the working surfaces. Mat.: CK 50 (50-52 HRC)★ - Mat.: UNI EN 10083/1 - ISO 683 - (42CrM04) - (53-60 HRC)★★

★★ 2012 / A / 90°

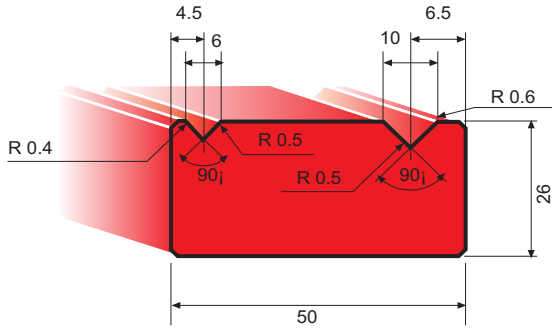

SOLID 80 T / m



★ 2012 / 60°

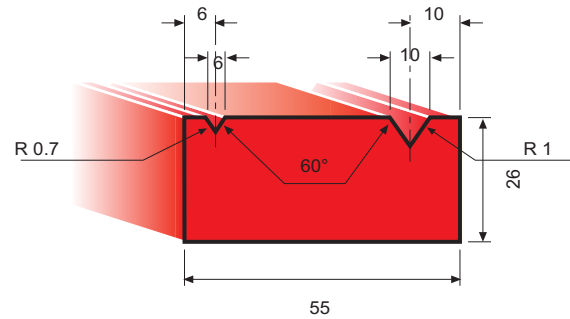

SOLID 80 T / m



★ 2012 / 35°

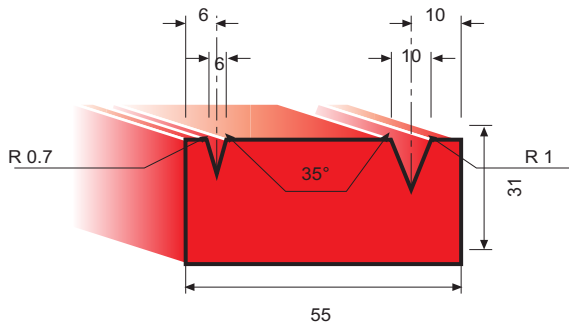

SOLID 30 T / m



★ 2013 / 90° / 88°

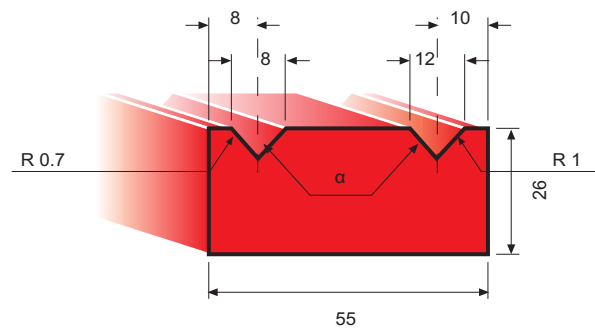

SOLID 100 T / m



★★ 2013 / A / 90°

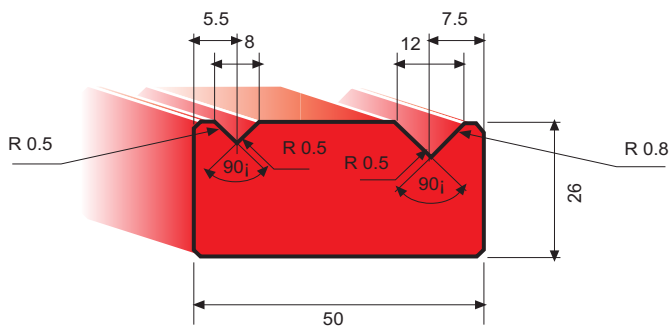

SOLID 80 T / m



★ 2013 / 60°

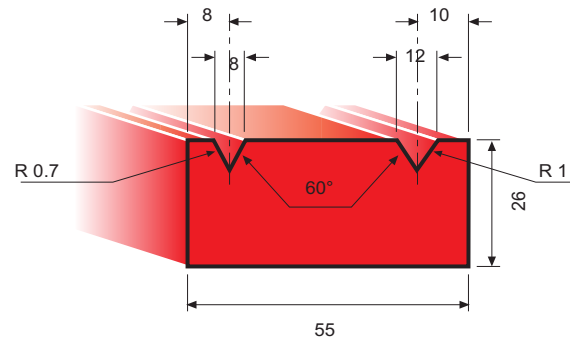

SOLID 80 T / m



Abkantwerkzeuge in bester Qualität, induktionsgehärtet -
Arbeitsflächen geschliffen. Mat.: CK 50 (50-52 HRC)★ - Mat.:
UNI EN 100083/1 - ISO 683 - (42CrM04) - (53-60 HRC)★★

Outils de pliage de qualite suprieure tremp s par induction
avec faces principales rectifi es. Mat.: CK 50 (50-52 HRC)★ -
Mat.: UNI EN 100083/1 - ISO 683 - (42CrM04) - (53-60 HRC)★★

★ 2013 / 35°

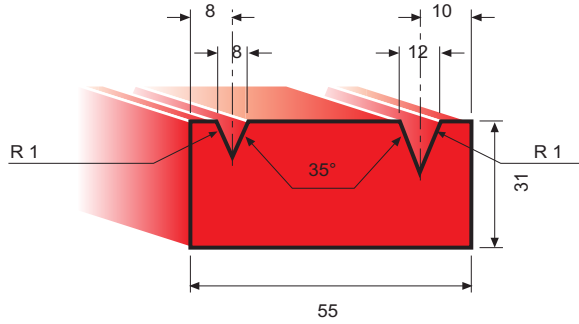

SOLID 30 T / m



★ 2014 / 88°

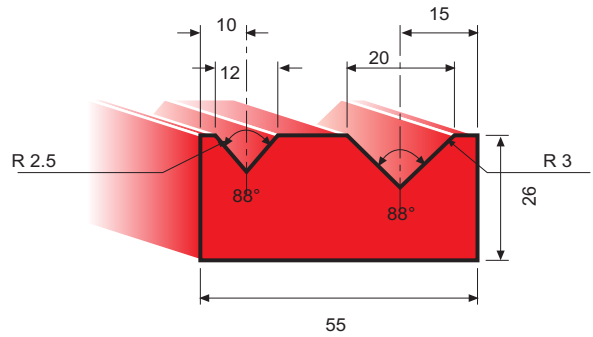

SOLID 100 T / m



★★ 2014 / A / 88°

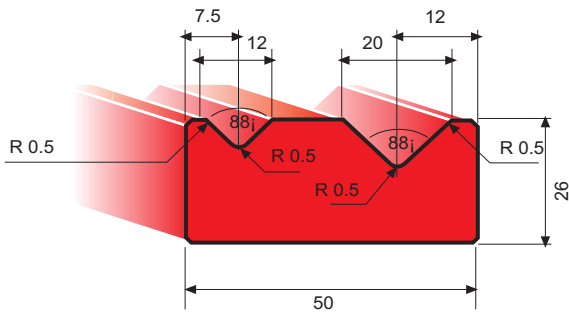

SOLID 80 T / m



★ 2014 / 60°

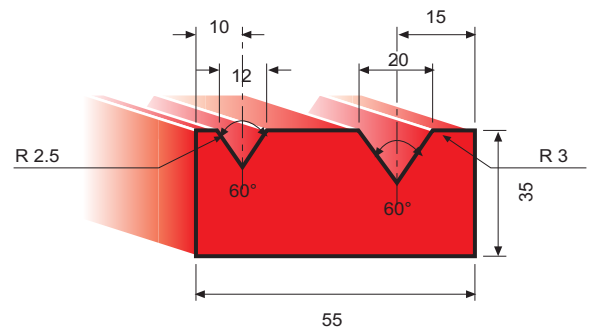

SOLID 80 T / m



★ 2015 / 88°

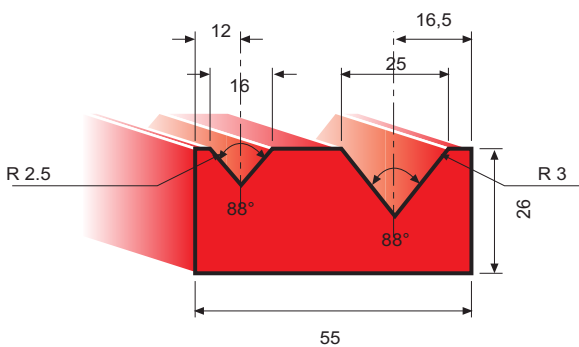

SOLID 100 T / m



★★ 2015 / A / 88°

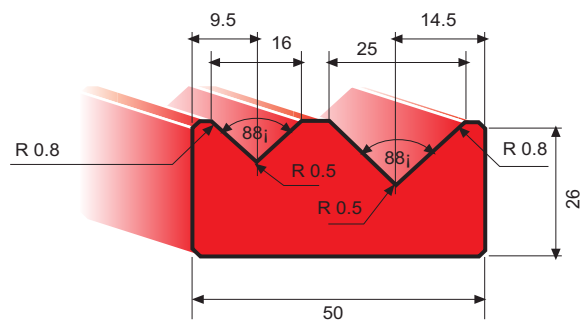

SOLID 80 T / m



Lunghezza Standard:
Standard Length:
Standardl ngen:
Longueur Standard:

835 mm; 415 mm; 835 frazionati
835 mm; 415 mm; 835 sectioned
835 mm; 415 mm; 835 sektioniert
835 mm; 415 mm; 835 fraktionn

★ 2015 / 60°

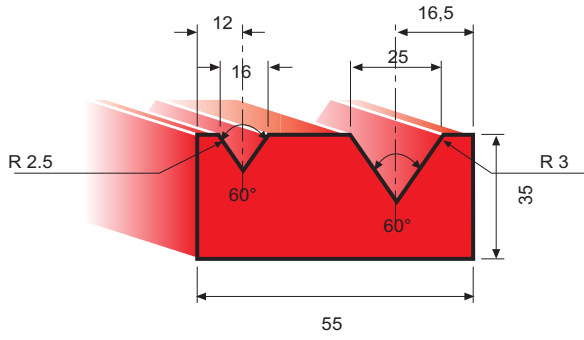

SOLID 80 T / m



★ 2016 / α

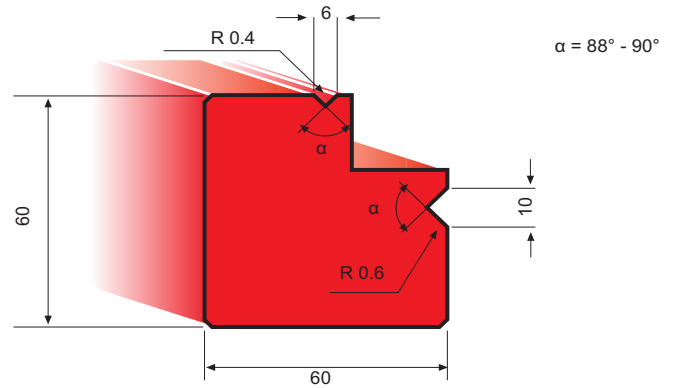

SOLID 70 T / m



★ 2017 / α

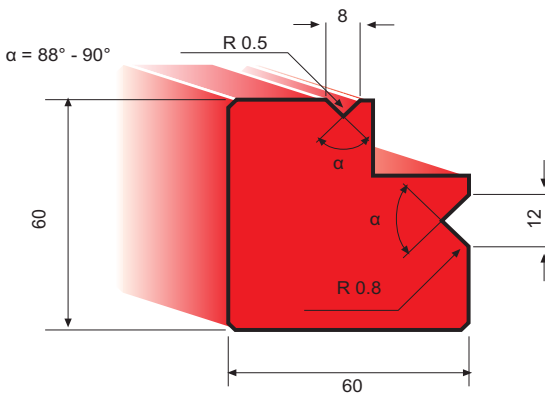

SOLID 70 T / m



★ 2030 / 30°

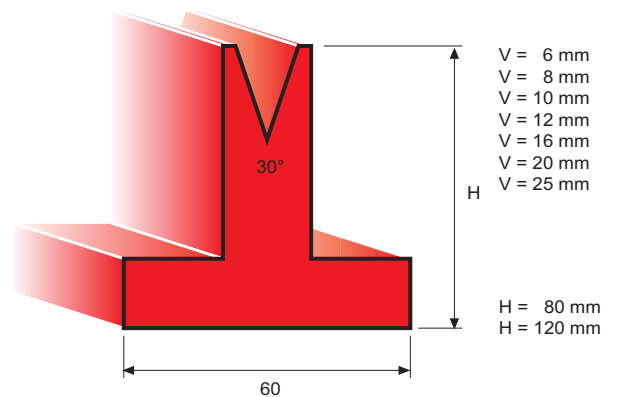

SOLID 30 T / m



★ 2035 / 35°

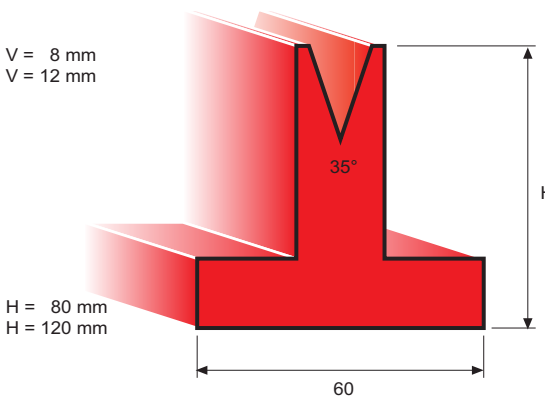

SOLID 30 T / m



★ 2045 / 45°

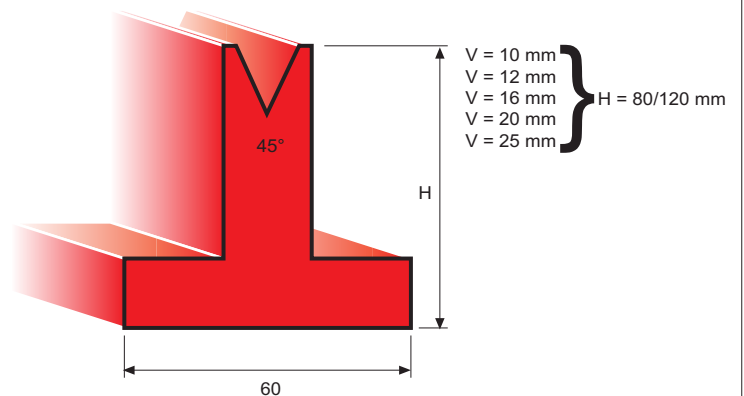

SOLID 70 T / m



Utensili per presse piegatrici realizzati con standards di qualità superiore, temprati a induzione sulle parti di lavoro e totalmente rettificati. Mat.: acciaio C 50 (50-52 HRC) ★ - Mat.: UNI EN 10083/1 - ISO 683 - (42CrM04) - (53-60 HRC)★★

Press Brake Tooling in best quality, induction hardened and ground on the working surfaces. Mat.: CK 50 (50-52 HRC)★ - Mat.: UNI EN 10083/1 - ISO 683 - (42CrM04) - (53-60 HRC)★★

★ 2060 / 60°

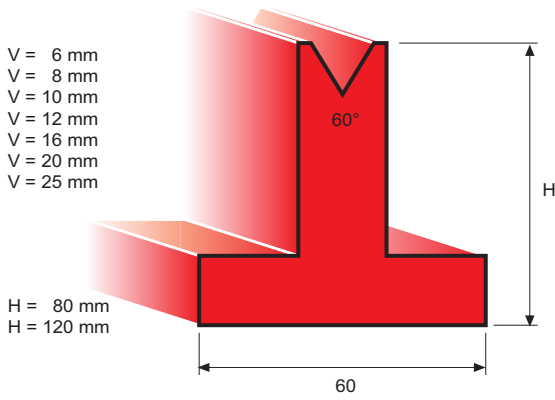

SOLID 70 T / m



★ 2088 / 88°

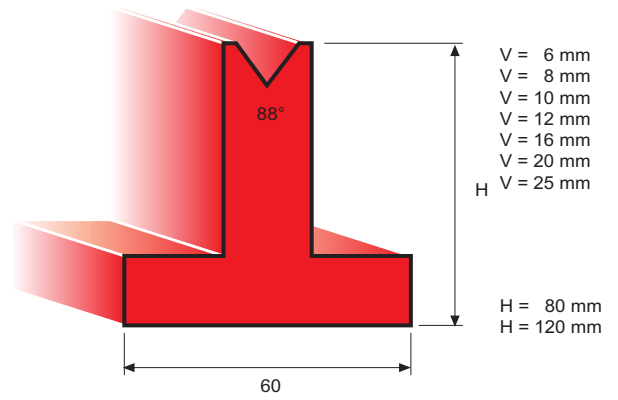

SOLID 95 T / m



★ 2090 / 90°

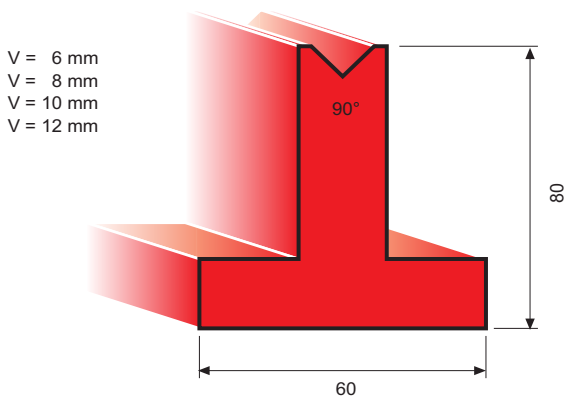

SOLID 95 T / m



★★ 2130 / A / 30°

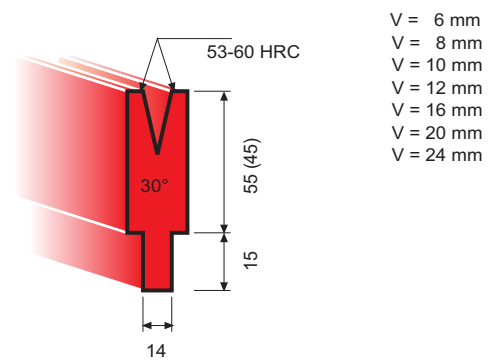

SOLID 30 T / m



★★ 2188 / A / 88°

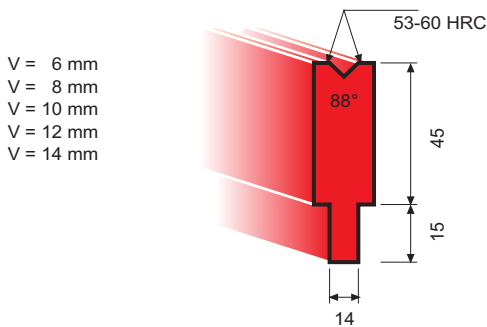

SOLID 95 T / m



★★ 2190 / A / 90°

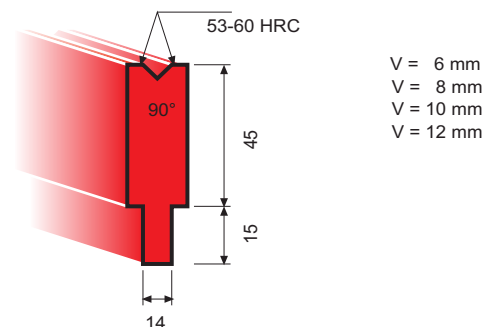

SOLID 95 T / m



Abkantwerkzeuge in bester Qualität, induktionsgehärtet -
Arbeitsflächen geschliffen. Mat.: CK 50 (50-52 HRC)★ - Mat.:
UNI EN 100083/1 - ISO 683 - (42CrM04) - (53-60 HRC)★★

Outils de pliage de qualité supérieure trempés par induction
avec faces principales rectifiées. Mat.: CK 50 (50-52 HRC)★ -
Mat.: UNI EN 100083/1 - ISO 683 - (42CrM04) - (53-60 HRC)★★

★ ★★ 2019 / A / α

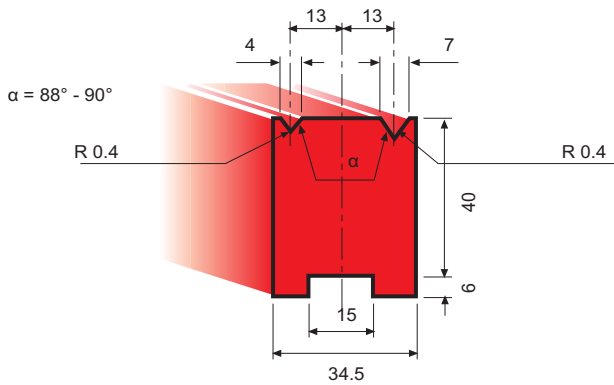

SOLID 60 T / m



★ ★★ 2020 / A / α

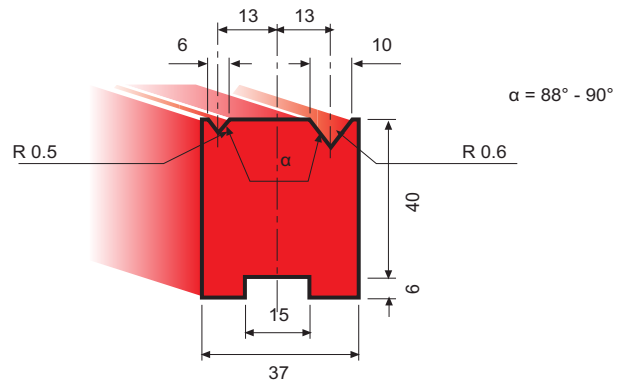

SOLID 70 T / m



★ ★★ 2021 / A / α

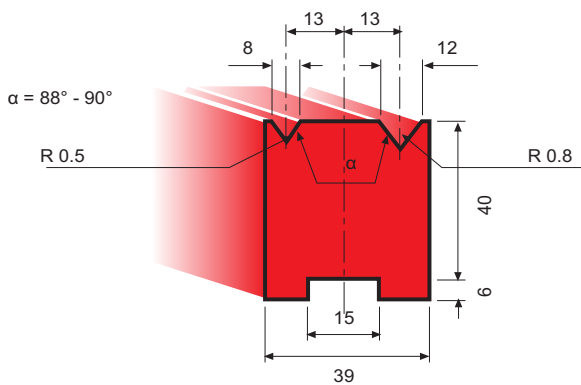

SOLID 75 T / m



★ ★★ 2022 / A / 88°

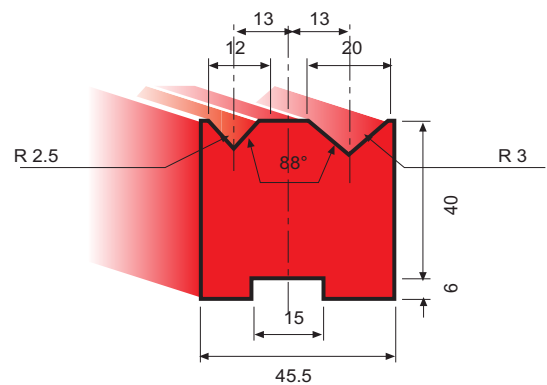

SOLID 100 T / m



★ ★★ 2023 / A / 88°

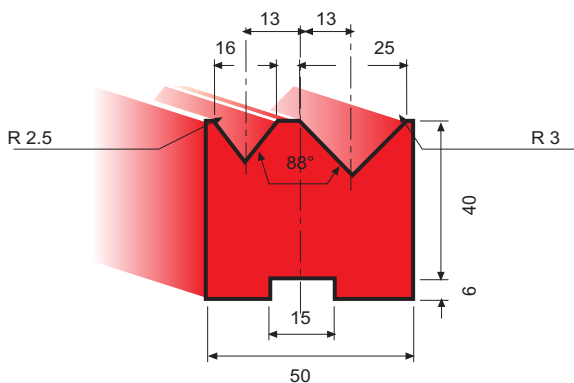

SOLID 100 T / m



★ ★★ 2024 / A / 88°

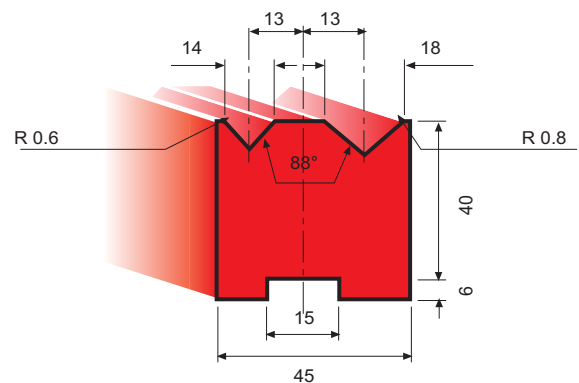

SOLID 100 T / m



Lunghezza Standard:
Standard Length:
Standardlängen:
Longueur Standard:

835 mm; 415 mm; 835 frazionati
835 mm; 415 mm; 835 sectioned
835 mm; 415 mm; 835 sektioniert
835 mm; 415 mm; 835 fractionn

★★ 2025 / A / 30°

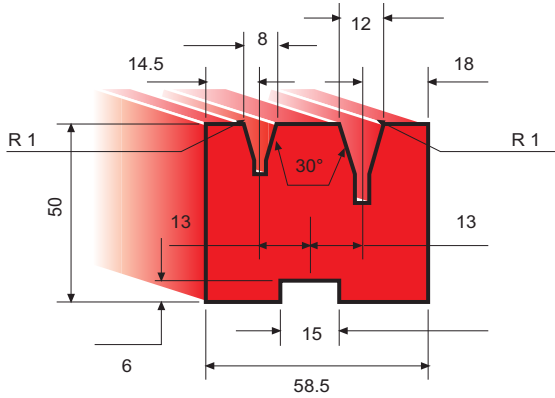

SOLID 30 T / m



★★ 2026 / A / 30°

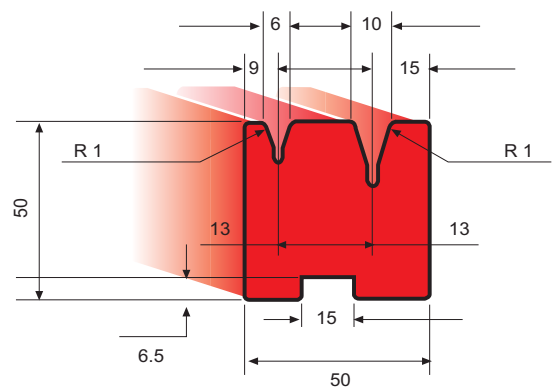

SOLID 30 T / m



★★ 2027 / A / 75°

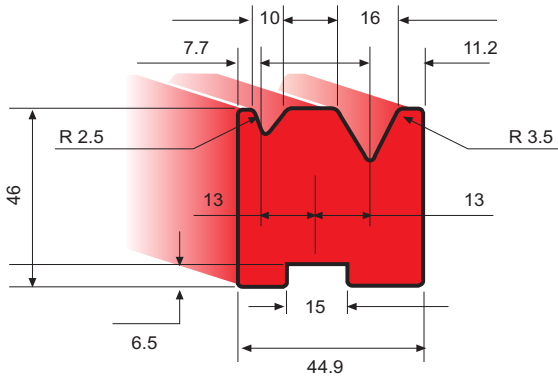

SOLID 30 T / m



★★ 2028 / A / 75°

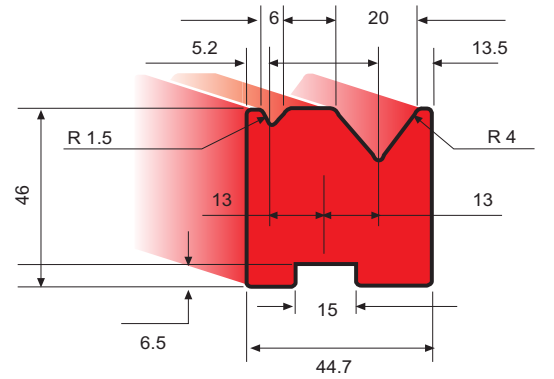

SOLID 30 T / m



★★ 2029 / A / 75°

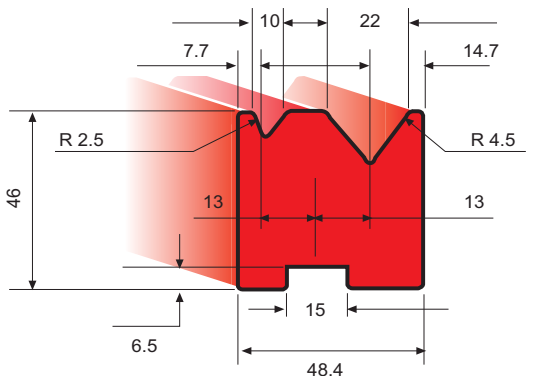

SOLID 30 T / m



★★ 2030 / A / 75°

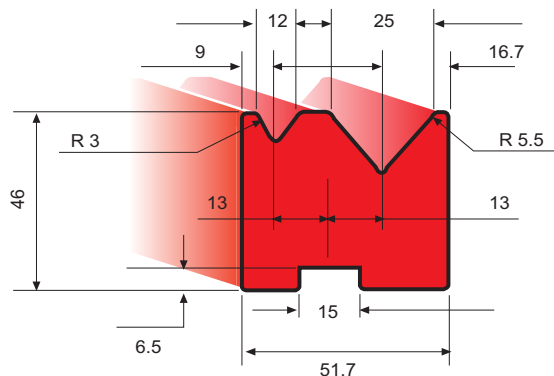

SOLID 30 T / m



Utensili piega - schiaccia Hemming Tooling

★ 3001 / 35°

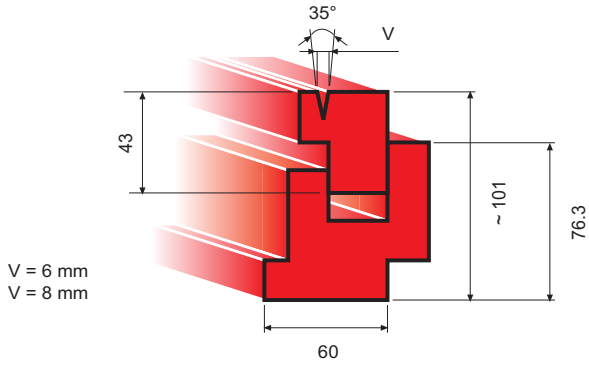

V = 6 mm
V = 8 mm

SOLID 60 T / m

★ 3001

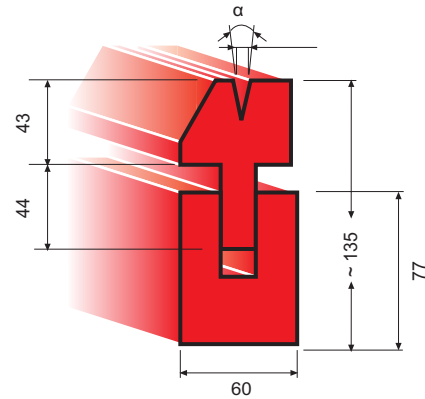

α
V = 10 mm / 26°
V = 10 mm / 35°
V = 12 mm / 35°

SOLID 100 T / m

★ 3001 / 12 / 26°

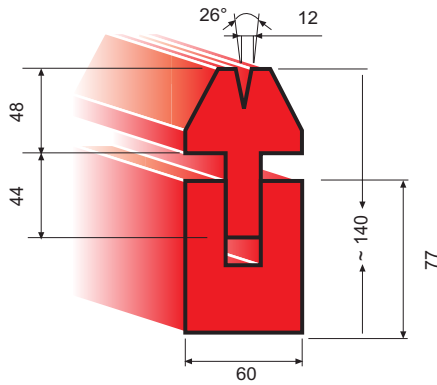

SOLID 100 T / m

★ 1033 / A / 28° / 0.6

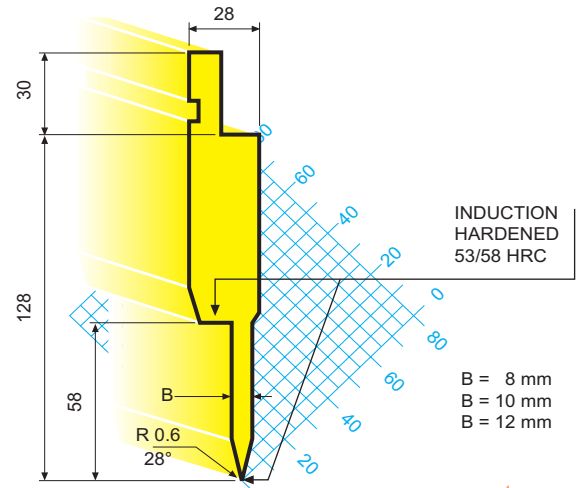

INDUCTION
HARDENED
53/58 HRC

B = 8 mm
B = 10 mm
B = 12 mm

SOLID 70 T / m

★ 3000

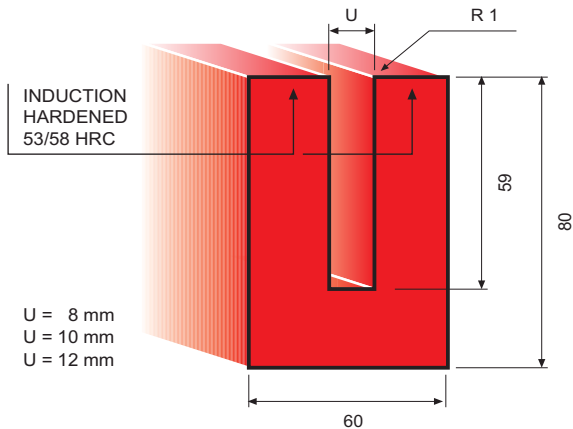

INDUCTION
HARDENED
53/58 HRC

U = 8 mm
U = 10 mm
U = 12 mm

SOLID 50 T / m

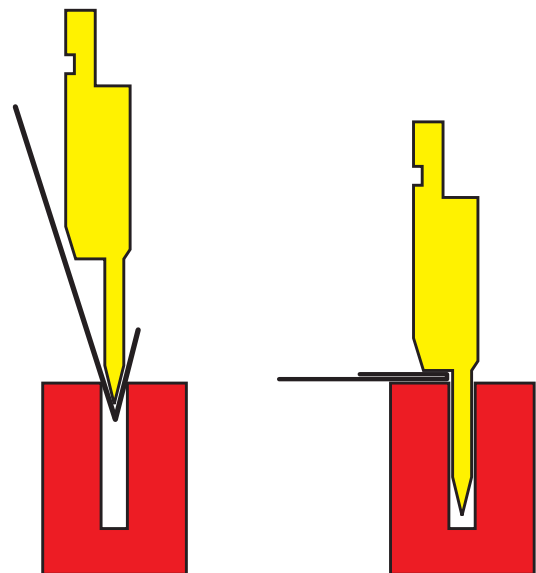

Piega - schiaccia pneumatici Pneumatic Hemming Tooling

★ 3001 / 8 / 30° / PN

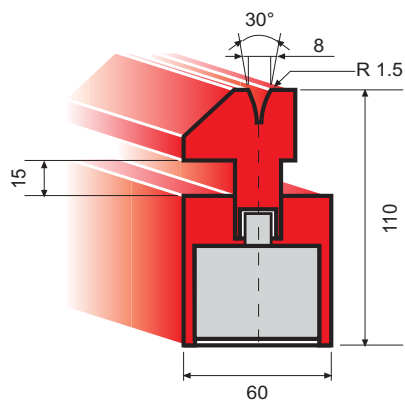

SOLID 80 T / m



★ 3001 / 8 / 35° / PN

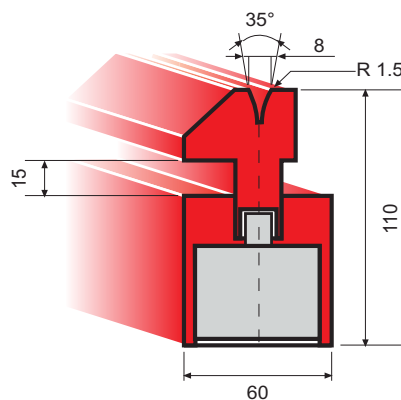

SOLID 80 T / m



★ 3001 / PN

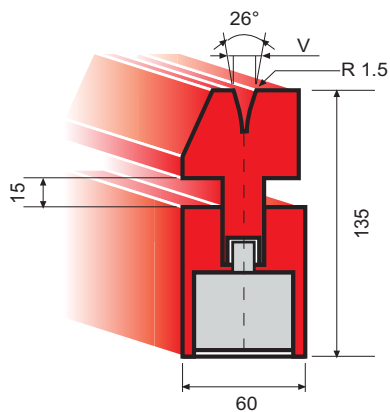

V = 10 / 26°
V = 10 / 35°
V = 12 / 35°

SOLID 100 T / m



★ 3001 / 12 / 26° / PN

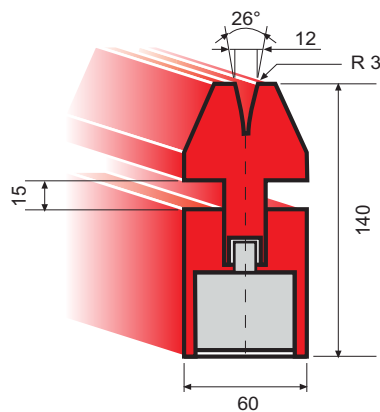

SOLID 100 T / m



CENTRALINA PNEUMATICA PNEUMATIC MOVING KIT

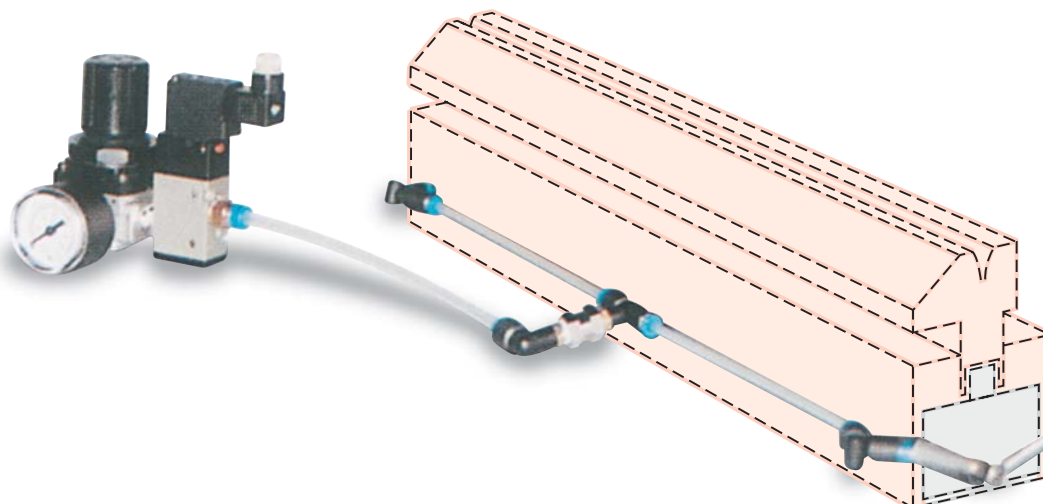



VARMAK MAKİNA
YENİ VE KULLANILMIŞ SANAYİ MAKİNALARI ALIM SATIM

351 Sok. No: 30 2. Sanayi Sitesi Bornova İZMİR/TÜRKİYE
Tel: 90 232 435 97 96 Fax: 90 232 486 57 70 Santral: 90 533 373 88 29
www.varmakmakina.com – info@varmakmakina.com